

HOLTOP
Fresh Air for Your Life

Heat & Energy Recovery Ventilators
Air to Air Heat Exchangers
Air Handling Units

ENERGY RECOVERY
VENTILATION
SOLUTIONS

Beijing Holtop Air Conditioning Co., Ltd.

No. 5 Yard, 7th Guanggu Street, Badaling Economic Development Zone, Yanqing District, Beijing, China

International Marketing Center

Room 2101, Headquarter Center No. 25, Tian An Hi-Tech Ecological Park, No. 555 Panyu Ave, Guangzhou, China

Tel: 86-20-39388201-8023

Skype: susanwoo08

Website: www.holtop.com

E-mail: info@holtop.com



* Data is subject to changes without notification due to product improvement

Holtop Profile

Holtop is the leading manufacturer in China specializing in the production of air to air heat recovery equipments. Founded in 2002, it is dedicated to the research and technology development in the field of heat recovery ventilation and energy saving air handling equipments for more than 20 years.

Holtop headquarters is located at the foot of Beijing Baiwangshan Mountain, covering area of 30,000 square meters. The manufacturing base is in Beijing's Badaling Economic Development Zone, covering an area of 60 acres, with an annual production capacity of 200,000 units of air heat recovery equipments. Holtop builds a sound certificate system of ISO9001, ISO14001 and OHSAS18001 as well as product certification systems. Moreover, it has a laboratory certified by national authority. As a well-known manufacturer in the field of heat recovery, Holtop has a strong R&D team and possesses dozens of national invention patents, and has participated in the compilation work of several national standards, and is also elected as Zhongguancun High-Tech Enterprise.

Holtop has mastered the core technology of heat recovery, independently developing products like plate and rotary heat exchangers, various heat & energy recovery systems and air handling units. Products have been exported to more than 100 countries and regions. Holtop continuously ranks the top in domestic market of heat and energy recovery ventilators.

Holtop will always committed to the mission of delivering highly efficient and energy saving products and solutions to improve indoor air quality, to ensure people's health and protect our earth.

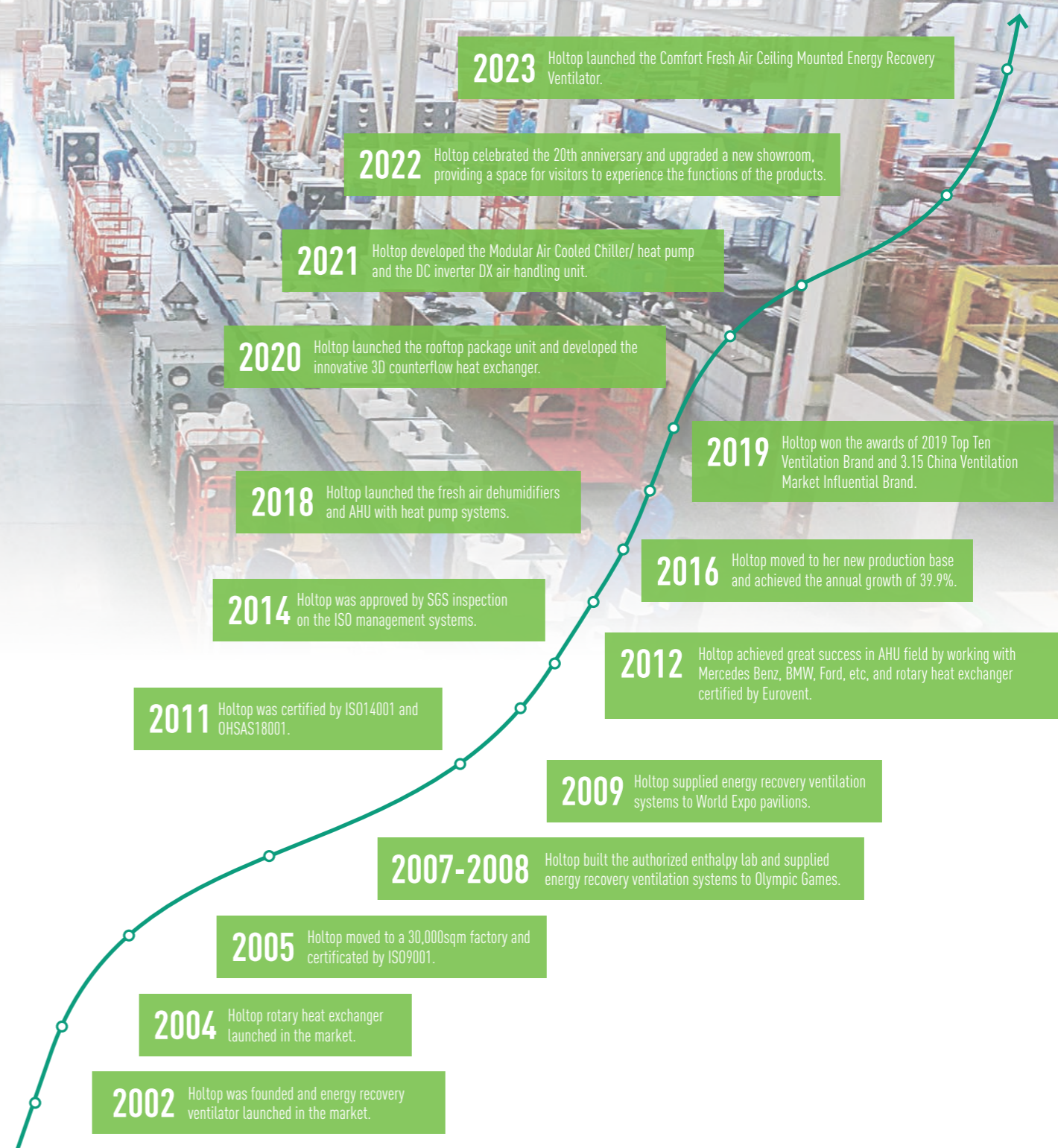

HOLTOP
FRESH AIR EXPERT
SINCE 2002

NO. 1
IN CHINA
200,000 UNITS
PER YEAR





Holtop Energy Recovery Ventilator

Energy recovery ventilators are central ventilation systems provide fresh air, remove indoor stale air and balance the humidity within a building. Besides, they can use the heat which recovered from the stale air to increase the incoming clean air to a comfortable temperature. These all help to create a clean and comfortable environment that enhances the well-being of building users.

Highlighted Features



High efficiency heat and humidity recovery for optimized comfort.



Professional air channel design and high quality components to make sure silence operation.



Multi-stage gradual filters to remove dust, PM2.5, bacteria and harmful substances



Providing fresh air all the time to make you feel breathing in the nature.



Easy installation and maintenance, 20% less thickness.



High energy saving, by reducing the load on the air conditioning system, delivering 40% energy savings compared with introducing untreated fresh air into a building.



Smart controller to decrease the energy costs of building with free cooling function, optional CO₂ sensor and humidity sensor to ensure proper ventilation while maintaining indoor comfort. Easy connection to central building control system.

Holtop Energy Recovery Ventilator Eco Family

Comfor Fresh Air

Eco-Smart

Eco-Clean

Eco-Vent

Ventilation Range Overview

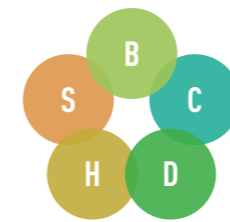

B By-pass

C Counterflow heat exchanger

D DC fan

H Sub-Hepa filter / Hepa filter











S Super slim design

Product Series	Installation Type	Main Features	Photo	Airtflow Range (m ³ /h)															
				150	200	250	300	350	400	500	600	650	800	1000	1300	1500	2000	2500	3000
Comfor Fresh Air																			
CFAC series	Suspended	B, C, D																	
CFA series	Wall Mounted	B, C, D																	
Eco-Smart																			
DMTHA series	Suspended	B, C, D																	
DMTHC series	Suspended	B, C, D																	
Eco-Clean																			
ERVQ-B150-1B1	Wall mounted	B, C, D																	
ERVQ-L300-1A1	Floor standing	B, C, D																	
ERVQ-L600-1A1																			
Eco-Vent																			
Eco-Vent Pro series	Suspended	B, C, D, S																	
TH series	Suspended	B, C, D																	
TZ series	Suspended	B, C, D																	
TG series	Suspended	-																	
PMTG series	Suspended	B, C, D																	



Comfort Fresh Air Ceiling Mounted Energy Recovery Ventilator

Comfort fresh air energy recovery ventilator is a new ventilation device that integrates air filtration and energy recovery. Composed of heat exchangers, filters, plastic-encapsulated DC fans and intelligent control system, it can effectively improve indoor air quality, increase indoor oxygen content, and at the same time greatly reduce the power load of indoor air-conditioning equipment, with high efficiency and energy saving.

-  DC Fan
-  10 Speeds
-  High ESP
-  Auto Bypass
-  5th Generation Heat Exchanger
-  New EPS Inner Structure
-  Optional SA/EA Air Direction
-  Occlusal Edge Sealing Technology
-  Intelligent Control
-  Wifi and IOT



CFAC Series

► Plastic-encapsulated DC Fans

The CFAC series ERV are built in plastic encapsulated brushless DC motor, which has higher processing precision and stable operation. Compared with traditional DC motor, the energy saving is up to 40%, resulting in lower power consumption, larger air volume and higher ESP.



► New EPS Inner Structure

Good thermal insulation, sealing and sound insulation. Central fans design make the better distribution of supply air and exhaust air, heat exchange of the core is more sufficient.

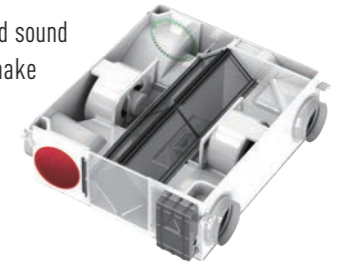

► New Processing Technology

Occlusal edge sealing technology, stronger casing strength, greatly reduce the screws, and improve the appearance.

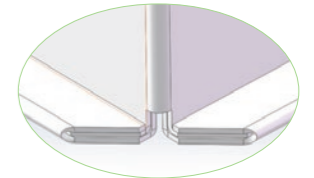

► The 5th Generation Enthalpy Heat Exchangers

5th generation thinner membrane, with better thermal conductivity and higher heat exchange efficiency. Resin installation rail, simple structure, good sealing performance. Integrated with primary filter and optional medium filter installation rail.

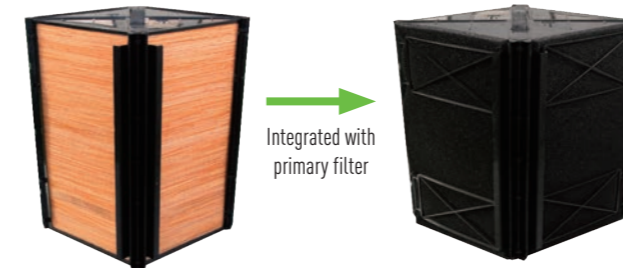

Integrated with primary filter

► Energy Efficiency Class of A or A⁺ According to EU NO. 1254/2014

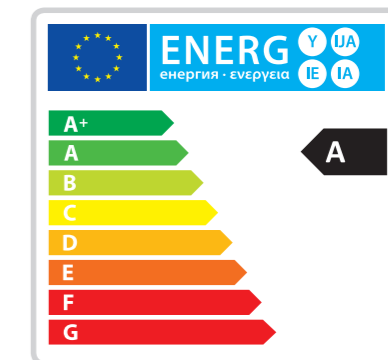

Specifications

Model	Rated Airflow (m ³ /h)	External Pressure (Pa)	Enthalpy Efficiency (%)		Temperature Efficiency (%)	Noise dB(A)	Voltage (V)	Power Input (W)	N.W. (kg)
			Cooling	Heating					
CFA 150C	150	95	71-79	73-79	80-84	29	220-240	58	20
CFA 250C	250	85	68-83	70-83	79-86	28	220-240	62	23
CFA 350C	350	160	71-82	72-84	80-89	32	220-240	140	30
CFA 500C	500	120	67-82	69-83	78-87	34	220-240	165	33
CFA 650C	650	120	66-81	69-82	77-86	35	220-240	252	38
CFA 800C	800	150	70-81	71-82	79-85	35	220-240	335	48
CFA 1000C	1000	170	71-86	73-87	80-90	37	220-240	420	54
CFA 1500C	1500	175	71-81	72-82	80-85	39	220-240	670	105
CFA 2000C	2000	150	71-86	73-87	80-90	40	220-240	850	117



► Flexible Installation

Left type or right type is optional. The installation type can be adjusted at site to meet different installation requirements.

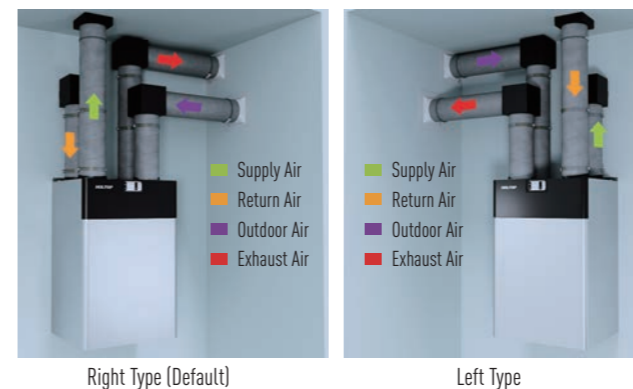

► Local Control Panel

There are two control panels on the machine body. Panel 1 is for daily simple settings and Panel 2 is for advanced parameter setting.

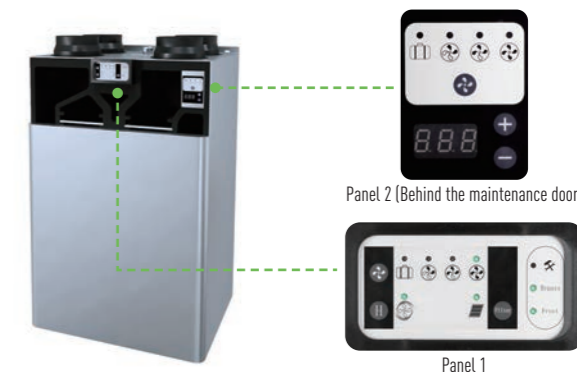

► Optional F7 Filter

HOLTOP Comfort Fresh air HRV is equipped with G4 filters. These filters remove 95% of the dust from the air. A more efficient F7 filter is available as an option.

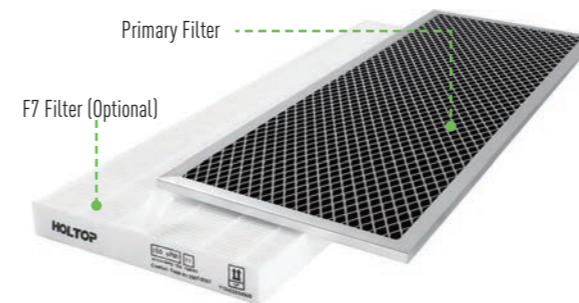

► Advanced LCD Remote Control Panel (Optional)



► 3D High Efficient Counterflow Heat Exchanger

Holtop counterflow heat exchanger has a distinct 3D heat exchange channel that allows heat to transfer in three directions. Heat recovery efficiency is up to 95%

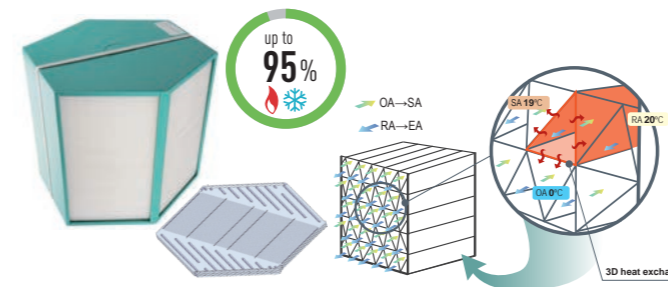

► Wifi Function Is Available For Control And Monitoring Of The Ventilation System From Anywhere (Optional)

SMART LIFE app is available at Google Play market and App Store.



Comfort Fresh Air Heat Recovery Ventilator

Holtop Comfort Fresh Air HRV brings in outdoor fresh air and creates a healthy living environment with oxygen, comfortable temperature and humidity. The efficiency of the built in plastic counterflow heat exchanger is up to 95%. It is suitable to be installed in cabinet, machine room, etc., the constant EC fans supply constant air volume despite the filters are dirty. It is a perfect ventilation system for residential application.

- Counterflow Heat Exchanger
- Efficiency up to 95%
- EC Constant Fans
- Left or Right Installation
- Standard 100% Bypass
- Eco-design A or A+
- Enthalpy Exchanger Available
- EPP Structure
- Intelligent Control
- Android / IOS APP



CFA Series







Specifications

Model	Rated Airflow (m ³ /h)	External Pressure (Pa)	Temperature Efficiency (%)	Noise dB(A)	Voltage (V)	Power Input (W)	N.W. (kg)
CFA 250T	250	130	95	35	230	137	40
CFA 350T	350	150	95	37	230	272	40
CFA 500T	500	160	95	39	230	412	50



Eco-Smart Energy Recovery Ventilator

Modern buildings are being built tightly to improve energy efficiency. Eco-smart ERV is ideal ventilation solution for energy efficient buildings to reduce ecological footprint and improve human health. The energy can be saved by using DC motors and improving energy efficiency with smart control system, to achieve eco friendly climatic experience.

- 
DC Motor
- 
High Efficiency Heat Exchanger
- 
G3+F9 Filter
- 
Different Pressure Gauge Alarm
- 
Auto Bypass
- 
Intelligent Control



XHBQ-D1.5DMTHA ~ XHBQ-D20DMTHA



XHBQ-D1.5DMTHC~XHBQ-D20DMTHC

- 
DC Motor
- 
10 Speeds
- 
Physical Filtering
- 
Energy Recovery
- 
Silent Operation
- 
Smart Control
- 
Filter Alarm
- 
Central Control
- 
IAQ Monitor
- 
WIFI Control

► Higher Energy Efficiency and Ecology by Powerful Motors

Full series Eco Smart energy recovery ventilator are built in higher efficiency brushless DC motors, power consumption is reduced by up to 70%, resulting in significant energy saving. VSD control which is suitable for most of the projects air volume and ESP requirement.

Running costs comparison of conventional ERV with AC motor and DC motor.

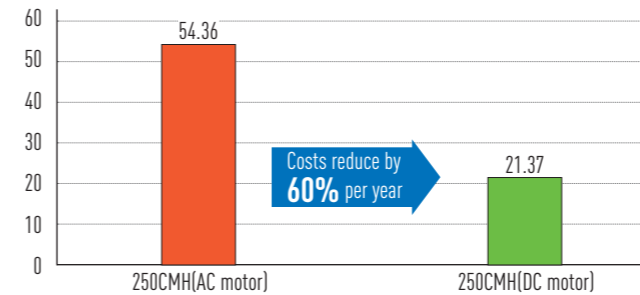

Conditions:

- Location: Beijing
- Airflow: 250m³/h
- Summer: 24h/day x 122days =2928h (Jun. To Sep.)
- Winter: 24h/day x 120days =2880h (Nov. To Mar.)
- Electric charge: 0.08 USD/Kw.h

► High Efficiency Heat Exchanger

High efficiency enthalpy heat recovery, more comfortable indoor climate.

► Linkage with External A/C System or BMS Control

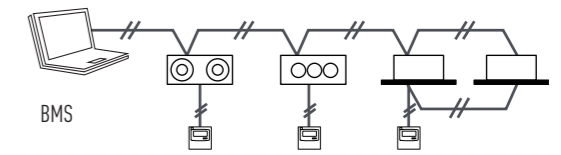

► Automatic Energy Recovery Ventilation or Nature Ventilation

In summer or winter when cooling or heating devices are in used. Bypass system is closed for energy recovery, when in spring or autumn when the outdoor temperature is soft, bypass system is open for nature ventilation.

► Energy Efficiency Class of A or A+ According to EU NO. 1254/2014

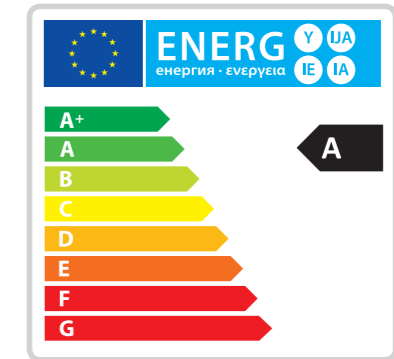

Specifications

Model	Rated Airflow (m ³ /h)	External Pressure (Pa)	Enthalpy Efficiency (%)		Temperature Efficiency (%)	Noise dB(A)	Voltage (V)	Power Input (W)	N.W. (kg)
			Cooling	Heating					
XHBQ-D1.5DMTHA	150	70	60-65	63-70	75-80	31.5	220-240	38	25
XHBQ-D2.5DMTHA	250	90	62-71	65-73	73-81	34.5	220-240	85	27
XHBQ-D3.5DMTHA	350	140	62-70	65-73	74-82	37.5	220-240	107	33
XHBQ-D5DMTHA	500	110	63-72	67-75	76-84	39	220-240	140	38
XHBQ-D6.5DMTHA	650	100	60-67	65-71	74-82	41	220-240	160	62
XHBQ-D8DMTHA	800	140	63-71	65-73	76-82	42	220-240	188	72
XHBQ-D10DMTHA	1000	140	60-68	62-72	76-82	43	220-240	312	81
XHBQ-D13DMTHA	1300	135	58-71	59-75	74-82	43	220-240	405	81
XHBQ-D15DMTHA	1500	95	63-71	65-73	76-80	50	220-240	700	147
XHBQ-D20DMTHA	2000	115	60-68	62-72	76-82	51.5	220-240	724	167

Model	Rated Airflow (m ³ /h)	External Pressure (Pa)	Enthalpy Efficiency (%)		Temperature Efficiency (%)	Noise dB(A)	Voltage (V)	Power Input (W)	N.W. (kg)
			Cooling	Heating					
XHBQ-D1.5DMTHC	150	70	60-65	63-70	75-80	31.5	220-240	43	25
XHBQ-D2.5DMTHC	250	90	62-71	65-73	73-81	34.5	220-240	80	27
XHBQ-D3.5DMTHC	350	140	62-70	65-73	74-82	37.5	220-240	116	33
XHBQ-D5DMTHC	500	110	60-74	63-78	76-85	39	220-240	230	35
XHBQ-D6.5DMTHC	650	110	63-72	65-76	74-85	41	220-240	363	54
XHBQ-D8DMTHC	800	140	63-71	65-75	76-85	42	220-240	368	62
XHBQ-D10DMTHC	1000	140	60-70	62-72	76-85	43	220-240	430	72
XHBQ-D15DMTHC	1500	95	63-71	65-75	76-85	50	220-240	700	147
XHBQ-D20DMTHC	2000	115	60-70	62-72	76-85	51.5	220-240	724	167

ECO-CLEAN FOREST

WALL MOUNTED ENERGY RECOVERY VENTILATOR



Multiple HEPA purification of 99%



Indoor&outdoor air filtration



High efficiency heat and humidity recovery



Silence Operation



High efficiency fans with DC motors



Remote control



Air quality Index(AQI) monitoring



Indoor slight positive pressure

Fresh Air
+Energy Recovery
+Purification



- Multiple HEPA purification of 99%
- Indoor&outdoor air filtration
- High efficiency heat and humidity recovery
- Indoor slight positive pressure
- High efficiency fan with DC motors
- Air quality Index(AQI) monitoring
- Silence operation
- Remote control

Innovative Multiple Filtration

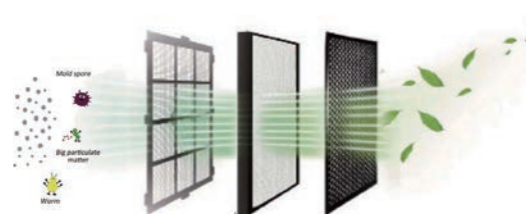

SMART LIFE app is available at Google Play market and App Store.



Specifications

Model	Air Quality Display	Airflow (m³/h)	Fan Speed	Filtration Efficiency (%)	Temperature Efficiency (%)	Power Input (W)	Filteration Mode	Operational Mode	Control	Noise dB (A)	Size L*W*H (mm)	N.W. (kg)
ERVQ-B150-1B1 (H01)	PM2.5, Temperature and Relative Humidity	150	DC, 8 Speeds	99% HEPA	82	35	PM2.5 Purify / Deep Purify / Ultra Purify	Manual / Auto / Timer / Sleep	Touch Screen Panel / Remote Control / WiFi Control	23-36	450*155*660	10
ERVQ-B150-1B1 (H02)	CO2, Temperature and Relative Humidity	150	DC, 8 Speeds	99% HEPA	82	35						



Eco-Clean Forest Vertical Energy Recovery Ventilator

- Multiple filtration
- 99% HEPA filtration
- Slight positive indoor pressure
- Colorful design
- High efficiency energy recovery rate
- High efficiency fan with DC motors
- Visual management LCD display
- Remote control

Specifications

Model	ERVQ-L300-1A1F	ERVQ-L600-1A1F
Airflow (m³/h)	300	600
Filtration efficiency (%)	99%, HEPA	99%, HEPA
Filtration mode	Pm2.5 purify / Deep purify / Ultra purify	Pm2.5 purify / Deep purify / Ultra purify
Fan Speed	DC, 8 speeds	DC, 8 speeds
Input Power (w)	70	125
Temperature Efficiency (%)	82	82
Noise dB(A)	25-36	25-36
Control	Touch screen panel & Remote control	Touch screen panel & Remote control
Air Quality Display	PM2.5, Temp & R.H	PM2.5, Temp & R.H
Operational Model	Manual / Auto / Timer	Manual / Auto / Timer
Suitable Room Size (m²)	50 - 120	100 - 240
Size (L*W*H) (mm)	560*410*1580	560*460*1700
Weight (kg)	55	65

Direct blown without duct installation



Suitable for living room, large bedroom, hospital, gum room, class room, kindergarten, etc..



Eco-Vent Pro Energy Recovery Ventilator

- Fresh Air Supply
- EPS Structure
- Smart Control
- Energy Recovery
- Easy Access
- Stale Air Exhaust
- Durable
- Filter Alarm
- Physical Filtering
- Good Insulation
- IAQ Monitor
- Silent Operation
- Central Control
- Slim Design



► Easy Maintenance

Two professional access doors for the control and fan maintenance.

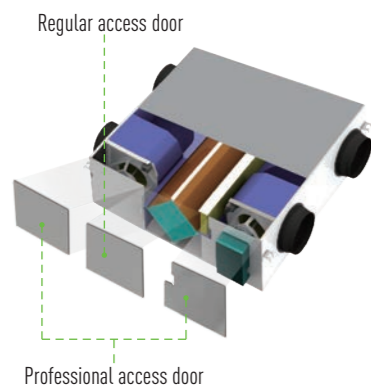

► Good Thermal Insulation

The whole series are integrated with EPS structure, effectively preventing condensation, and improving thermal insulation and saving energy consumption.

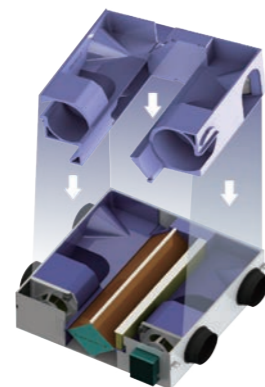

► Optional Sub-HEPA F9 Filter

Optional sub HEPA F9 filter, particle diameter under 2.5µm can be filtered effectively, IAQ (indoor air quality) will be increased obviously.

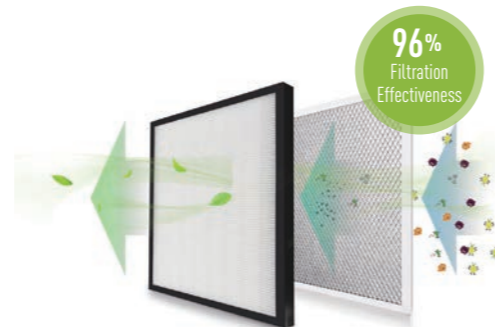

► High Efficiency Enthalpy Heat Exchanger

The enthalpy heat exchanger is made of the latest nanofiber structure to ensure higher efficiency. The heat exchange materials are mildew resistance and fire retardance.



Specifications

Eco-vent Pro series ERV with sub-HEPA F9 filter (PM2.5 filter)

Model	Airflow (m³/h)	External Pressure (Pa)	Enthalpy Efficiency (%)		Temperature Efficiency (%)	Noise dB(A)	Voltage (V)	Power Input (W)	N.W. (kg)
			Cooling	Heating					
ERVQ-D150-2A1	120	45	61	75	82	23	220	93	29
	150	70	59	73	80	31		98	
	150	90	59	73	80	31.5		102	
ERVQ-D250-2A1	210	35	57	70	75	26.5	220	123	32
	250	50	55	68	73	33.5		148	
	250	100	55	68	73	34		150	
ERVQ-D350-2A1	240	40	62	73	81	31	220	209	42
	350	110	57	68	76	36.5		230	
	350	130	57	68	76	37		233	
XHBQ-D6PMTHC	500	79	63	67	76	29	220	195	35
	600	82	59	61	70	35		39	
	600	87	59	61	70	39		39	
XHBQ-D8PMTHC	700	82	57	63	74	34	220	420	54
	800	86	55	57	68	39		41	
	800	90	55	57	68	41		41	
XHBQ-D10PMTHC	900	70	60	64	76	34	220	450	62
	1000	75	58	62	70	38		42	
	1000	76	58	62	70	42		42	
XHBQ-D13PMTHC	1000	65	58	62	76	38	220	680	72
	1300	75	56	59	70	41		43	
	1300	80	56	59	70	43		43	

Eco-vent Pro series ERV without sub-HEPA F9 filter (PM2.5 filter)

Model	Airflow (m³/h)	External Pressure (Pa)	Enthalpy Efficiency (%)		Temperature Efficiency (%)	Noise dB(A)	Voltage (V)	Power Input (W)	N.W. (kg)
			Cooling	Heating					
ERVQ-D150-2B1	120	45	61	75	82	23	220	93	29
	150	70	59	73	80	31		98	
	150	90	59	73	80	31.5		102	
ERVQ-D250-2B1	210	35	57	70	75	26.5	220	123	32
	250	50	55	68	73	33.5		148	
	250	100	55	68	73	34		150	
ERVQ-D350-2B1	240	40	62	73	81	31	220	209	42
	350	110	57	68	76	36.5		230	
	350	130	57	68	76	37		233	
XHBQ-D6THC	500	89	63	67	76	29	220	200	34
	600	92	59	61	70	35		39	
	600	97	59	61	70	39		39	
XHBQ-D8THC	700	92	57	63	74	34	220	420	53
	800	96	55	57	68	39		41	
	800	100	55	57	68	41		41	
XHBQ-D10THC	900	80	60	64	76	34	220	450	61
	1000	85	58	62	70	38		42	
	1000	86	58	62	70	42		42	
XHBQ-D13THC	1000	75	58	62	76	38	220	680	71
	1300	85	56	59	70	41		43	
	1300	90	56	59	70	43		43	



Eco-Vent Energy Recovery Ventilator

TH Series

- Airflow from 150-1300 m³/h
- Energy recovery
- Crossflow heat exchanger
- Quiet operation
- Double filters
- Easy installation to ceiling
- By-pass function



XHBQ-D2TH ~ XHBQ-D13TH

Installation

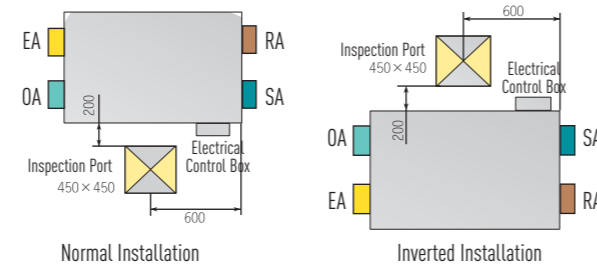
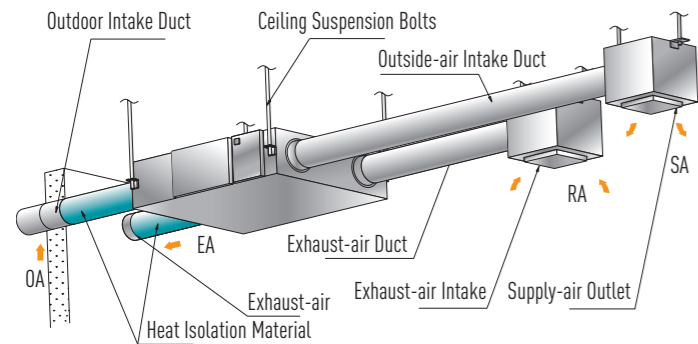

Specifications

Model	Airflow (m ³ /h)			External Pressure (Pa)			Enthalpy Efficiency (%)						Temp. Efficiency (%)			Noise dB(A)			Volt. (V)	Current (A)	Input Power (W)	N. W. (Kg)
	L	M	H	L	M	H	Summer			Winter			L	M	H	L	M	H				
XHBQ-D2TH	150	200	200	60	70	75	60	55	55	63	59	59	75	70	70	25	30	31.5	220	0.5	105	23
XHBQ-D3TH	250	300	300	75	82	85	62	57	57	65	61	61	73	68	68	27	34	34.5	220	0.56	117	25
XHBQ-D4TH	350	400	400	80	85	88	62	57	57	65	60	60	74	69	69	31	37	37.5	220	0.72	150	31
XHBQ-D6TH	500	600	600	89	92	97	63	59	59	67	61	61	76	70	70	29	35	39	220	0.96	200	36
XHBQ-D8TH	700	800	800	92	96	100	57	55	55	63	57	57	74	68	68	34	39	41	220	1.7	355	60
XHBQ-D10TH	900	1000	1000	80	85	86	60	58	58	64	62	62	76	70	70	34	38	42	220	2.1	440	70
XHBQ-D13TH	1000	1300	1300	75	85	90	58	56	56	62	59	59	76	70	70	38	41	43	220	3.4	710	79

TZ Series

- Airflow from 800-1000 m³/h
- Energy recovery
- High ESP construction
- Quiet operation
- Double filters
- Easy installation to ceiling
- By-pass function



XHBQ-D8TZ ~ XHBQ-D10TZ

Specifications

Model	Airflow (m ³ /h)			External Pressure (Pa)			Enthalpy Efficiency (%)						Temp. Efficiency (%)			Noise dB(A)			Volt. (V)	Current (A)	Input Power (W)	N. W. (Kg)
	L	M	H	L	M	H	Summer			Winter			L	M	H	L	M	H				
XHBQ-D8TZ	680	800	800	120	125	170	58	55	55	64	57	57	75	68	68	37	40	43	220	2.8	585	60
XHBQ-D10TZ	840	1000	1000	105	120	175	60	57	57	63	61	61	75	69	69	36	42	44	220	3.3	690	79

TG Series / PMTG Series

- Improved design with higher ESP
- Double-skinned panel with 20 mm PU insulation
- Innovative access space design
- Quiet operation
- Energy recovery
- TG series G3 FILTER, PMTG series G3+F9 FILTERS



Specifications

Model	Airflow (m ³ /h)			External Pressure (Pa)			Enthalpy Efficiency (%)						Temp. Efficiency (%)			Noise dB(A)			Input Power (W)			N. W. (Kg)
	L	M	H	L	M	H	Summer			Winter			L	M	H	L	M	H	L	M	H	
XHBQ-D15TG	1000	1500	1500	84	135	163	69	66	66	74	70	70	74	71	71	46	49	51	485	740	785	110
XHBQ-D20TG	1200	2000	2000	110	132	176	65	62	62	73	71	71	74	71	71	49	51	53	650	980	1020	112
XHBQ-D25TG	2000	2500	2500	140	170	200	64	61	61	72	70	70	73	70	70	50	52	55	940	1250	1300	130
XHBQ-D30TG	2500	3000	3000	150	180	210	63	60	60	71	69	69	73	70	70	51	54	57	1400	1870	1950	162
XHBQ-D15PMTG	1000	1500	1500	74	125	153	69	66	66	74	70	70	74	71	71	46	49	51	485	740	785	115
XHBQ-D20PMTG	1200	2000	2000	95	116	160	65	62	62	73	71	71	74	71	71	49	51	53	650	980	1020	117
XHBQ-D25PMTG	2000	2500	2500	125	155	185	64	61	61	72	70	70	73	70	70	50	52	55	940	1250	1300	137
XHBQ-D30PMTG	2500	3000	3000	135	165	195	63	60	60	71	69	69	73	70	70	51	54	57	1400	1870	1950	150

Fresh Air Filtration System

- Double filters, PM2.5 filtration over 99%
- Zinc free galvanized steel plate, high corrosion resistance and long service life
- Built-in low-noise AC or DC blower
- High efficiency motor, running smoothly with low noise
- Super thin design and fit for installation



DX1.5B4 ~ DX3.5B4

Specifications

Model	Airflow (m ³ /h)		External Pressure (Pa)		Input Power (W)		Current (A)		Noise dB(A)		Power supply	Weight (Kg)
	L	H	L	H	L	H	L	H	L	H		
DX1.5B4	100	150	55	80	40	57	0.25	0.31	25	32	220V/50Hz	8
DX2.5B4	150	250	60	100	68	85	0.3	0.45	30	34	220V/50Hz	8
DX3.5B4	200	350	100	120	108	154	0.58	0.85	32	37	220V/50Hz	10.5

Accessories List

Product Series		Installation Type	Primary Filter	PM2.5 Filter (F9)	F7 Filter	H10 Filter	H13 Filter	Bypass	PM2.5 Sensor	CO2 Sensor	Humidity Sensor	WiFi Module
Comfort Fresh Air	CFAC series	Suspended	✓	○	○	○	○	✓	-	○	○	○
	CFA series	Wall Mounted	✓	○	○	○	○	✓	-	○	✓	○
Eco-Smart	DMTHA series	Suspended	✓	✓	○	○	○	✓	-	○	○	○
	DMTHC series	Suspended	✓	✓	○	○	○	✓	-	○	○	○
Eco-Clean	ERVQ-B150-1B1	Wall mounted	✓	✓	○	✓	○	-	○	○	✓	✓
	ERVQ-L300-1A1	Floor standing	✓	✓	○	✓	○	-	○	-	✓	-
	ERVQ-L600-1A1		✓	✓	○	✓	○	-	○	-	✓	-
Eco-Vent	Eco-Vent Pro series	Suspended	✓	○	○	○	○	✓	-	○	○	○
	TH series	Suspended	✓	-	-	-	-	✓	-	○	○	○
	TZ series	Suspended	✓	-	-	-	-	✓	-	○	○	○
	TG series	Suspended	✓	-	-	-	-	-	-	○	○	○
	PMTG series	Suspended	✓	✓	○	○	○	-	-	○	○	○

Note: "✓" Standard, "○" Optional, "-" Not available.

Control System

Controller	B-14000	LH-12130	13002	10307	HDK-CK-20A	HDK-CK-50A
Suitable Series	DMTHA, TH, TZ, TG, PMTG			DMTHC, Eco-Vent Pro, CFAC		CFA
Temp. Display	OA/RA/SA/FR Temp.					
Optional IAQ Sensor	CO2, Humidity, PM2.5, HCHO	CO2, Humidity	CO2, Humidity, PM2.5	CO2	CO2, Humidity	CO2, Humidity
Speed Selection	✓	✓	✓	✓	✓	✓
Timer ON/OFF	✓	✓	✓	✓	✓	✓
Bypass	Auto	Auto	Auto	Auto	Auto	Auto
Comfortable	✓	✓	✓	✓	✓	✓
Defrosting	✓	✓	✓	✓	✓	✓
Filter Alarm	✓	✓	✓	✓	✓	✓
Fault Alarm	✓	✓	✓	✓	✓	✓
Sleep Mode	✗	✗	✗	✗	✓	✓
BMS Integration	✓	✓	✓	✓	✓	✓
Humidity Control	✓	✓	✓	✗	✓	✓
Defrosting	✓	✓	✓	✓	✓	✓
WiFi Function	✓	✓	✓	✓	✓	✓

Note: TG and PMTG series is without bypass.

WiFi Functions

► Monitoring Indoor Air Quality

Monitor the local weather, temperature, humidity, CO2 concentration, VOC at your fingertips for a healthy life.

► Variable Setting

Timer, speed settings, bypass, timer, filter alarm, and temperature control are all available.

► Group Control

One APP can control multiple units.

► Download the APP for **SMART VENT** at Google Play market and App Store.



Rotary Heat Exchanger

Working Principle

Rotary heat exchanger is composed of alveolate heat wheel, case, drive system and sealing parts. The exhaust and outdoor air pass through half of the wheel separately, when the wheel rotates, the heat and moisture are exchanged between the exhaust and outdoor air. The energy recovery efficiency is up to 70% to 90%.

Main Features

- 3A molecular sieve coating of hygroscopic wheel selectively absorbs moisture and expels odors
- Interior spokes are used to mechanically bond the rotor's laminations.
- Double sealing system
- Double purge sector
- Self cleaning
- life-time-lubricated bearing of easy maintenance

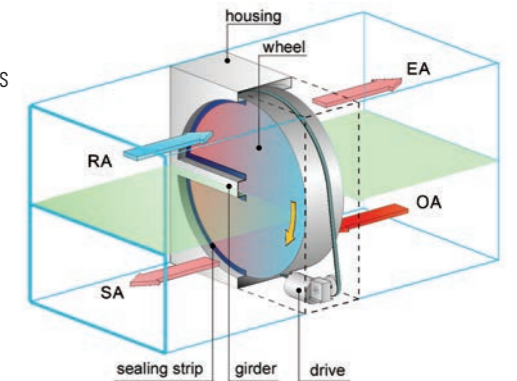

Specifications

Model HRT(S)-	Width A(mm)	Height B(mm)	Depth C(mm)	Diameter D(mm)	Motor Power (kw)	Weight (kg) Up-down type /Right-left type	Rotor cut	Casing construction	Diagram
500	600	600	340	530	0.09	42	One piece	Casing A, plate structure, made of aluzinc, one-piece	
600	700	700	340	630	0.09	59			
700	800	800	340	730	0.09	71			
800	900	900	340	830	0.09	82			
900	1030	1030	340	930	0.09	102			
1000	1130	1130	340	1030	0.09	130			
1100	1230	1230	340	1130	0.09	151			
1200	1330	1330	340	1230	0.18	169			
1300	1430	1430	340	1330	0.18	190			
1400	1530	1530	340	1430	0.18	205			
1500	1630	1630	340	1530	0.18	212/220			
1600	1730	1730	340	1630	0.18	230/239			
1700	1830	1830	340	1730	0.25	256/266			
1800	1930	1930	340	1830	0.25	283/293			
1900	2030	2030	340	1930	0.25	301/320			
2000	2130	2130	340	2030	0.25	358/370			
2200	2400	2400	400	2230	0.37	420	4 segments, Site assembly	Casing D Frame structure, made of aluminum profiles with aluzinc plates, in two sections, site assembly	
2400	2600	2600	400	2430	0.37	500			
2600	2800	2800	400	2630	0.37	570	8/16/24 segments, Site assembly	Casing E / F Frame structure, made of aluminum profiles with aluzinc plates. Caseing E is parts delivery and site assembly; Caseing F is complete delivery	
2800	3000	3000	400	2830	0.37	860			
3000	3200	3200	430	3030	0.55	950			
3200	3400	3400	430	3230	0.55	1039			
3400	3600	3600	430	3430	0.55	1110			
3600	3800	3800	430	3630	0.55	1220			
3800	4000	4000	430	3830	0.55	1360			
4000	4200	4200	430	4030	0.75	1500			
4200	4400	4400	430	4230	0.75	1645			
4400	4600	4600	430	4430	0.75	1750			
4600	4800	4800	430	4630	1.1	1830			
4800	5000	5000	430	4830	1.1	1980			
5000	5200	5200	430	5030	1.1	2100			

* Model HRT-xxx stands for hygroscopic wheel, model HRS-xxx standds for sensible heat wheel.



Crossflow Plate Heat Exchanger

Working Principle

Two neighbor aluminum foils form a channel for fresh or exhaust air stream. Heat is transferred when the air streams flow crossly through the channels, and fresh air and exhaust air is totally separated.



Main Features

- Sensible heat recovery
- Total separation of fresh air & exhaust air streams
- Heat recovery efficiency up to 80%
- 2-side press shaping
- Double folded edge
- Completely joint sealing.
- Resistance of pressure difference up to 2500Pa
- Under pressure of 700Pa, air leakage less than 0.6%

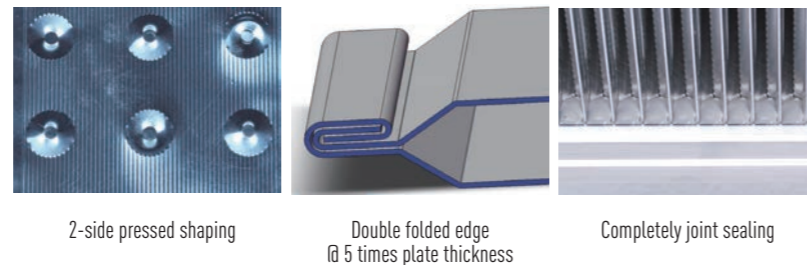

Specifications

Model	Ref. airflow rang (m³/h)	A (mm)	C (mm)	Length per piece (L)	Optional spacing (mm)	Remarks
HBS-ZF250/250	400-2000	250	356	≤400	4.0	One module
HBS-ZF300/300	700-2700	300	427	≤400	4.0	
HBS-ZF300/300		300	427	≤500	5.0	
HBS-ZF350/350	1200-3000	350	498	≤400	4.0	
HBS-ZF350/350		350	498	≤500	5.0	
HBS-ZF350/350		350	498	≤550	6.0	
HBS-ZF400/400	1800-3500	400	568	≤400	4.0	
HBS-ZF400/400		400	568	≤500	5.0	
HBS-ZF400/400		400	568	≤550	6.0	
HBS-ZF500/500	2300-4000	500	710	≤550	6.0, 8.0, 10.0	
HBS-ZF600/600	2800-6000	600	851	≤550	6.0, 8.0, 10.0	
HBS-ZF700/700	3500-7000	700	993	≤550	8.0, 10.0	
HBS-ZF800/800	5000-1000	800	1134	≤550	8.0, 10.0	
HBS-ZF1000/1000	7000-16000	1000	1417	≤500	6.0, 8.0, 10.0	
HBS-ZF1200/1200	11000-21000	1200	1702	≤500	6.0, 8.0, 10.0	
HBS-ZF1400/1400	15000-28000	1400	1985	≤500	8.0, 10.0	
HBS-ZF1600/1600	18000-37000	1600	2265	≤500	8.0, 10.0	

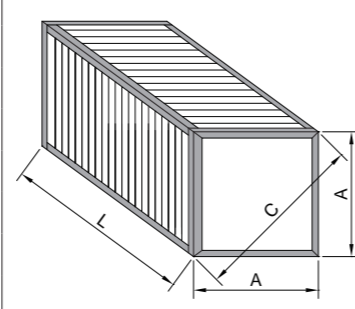

Remarks

1. Length is customized, but should be within the specified range.
2. Size C is for reference, size can be slightly increased according to heat exchanger length.

Crossflow Total Heat Exchanger

Working Principle

The flat plates and the corrugated plates form channels for fresh or exhaust air stream. When the two air streams passing through the exchanger crossly with temperature difference, the energy is recovered.

Main Features

- Heat recovery efficiency up to 85%
- Enthalpy efficiency up to 76%
- Effective air exchange rate over 98%
- Selective molecule permeability
- Flame retardant and mildew resistance

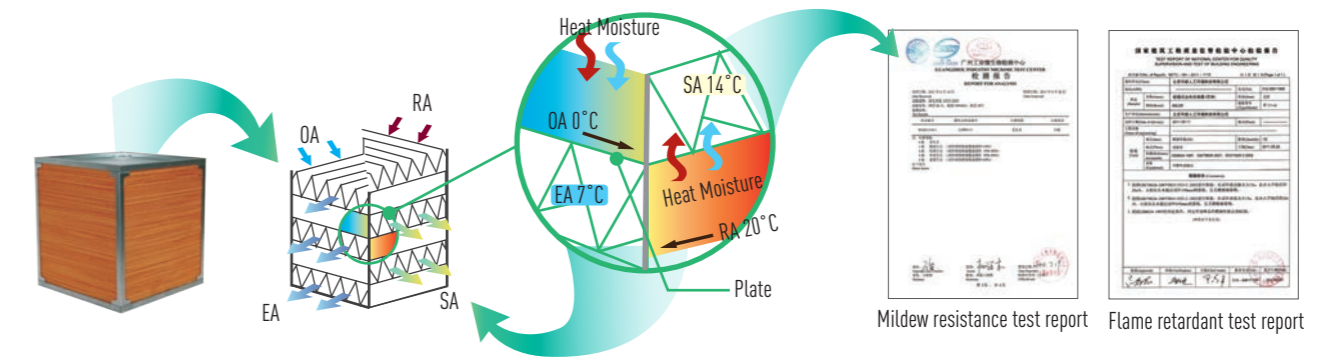

Specifications

Model	A (mm)	L (mm)	C (mm)	Optional corrugation height (mm)	Remarks
HBT-W168/168	168	≤500	240	2.0, 2.5	One module
HBT-W202/202	202	≤500	288	2.0, 2.5	
HBT-W222/222	222	≤500	317	2.0, 2.5	
HBT-W250/250	250	≤700	356	2.0, 2.5, 3.5	
HBT-W300/300	300	≤700	427	2.0, 2.5, 3.5	
HBT-W350/350	350	≤700	498	2.5, 3.5	
HBT-W372/372	372	≤700	529	2.5, 3.5	
HBT-W400/400	400	≤700	568	3.5	
HBT-W472/472	472	≤550	670	3.5	
HBT-W500/500	500	≤550	710	3.5	
HBT-W552/552	552	≤550	783	3.5	
HBT-W600/600	600	≤550	851	3.5	
HBT-W652/652	652	≤550	925	3.5	
HBT-W700/700	700	≤550	993	3.5	
HBT-W800/800	800	≤550	1134	3.5	
HBT-W1000/1000	1000	≤450	1417	3.5	
HBT-W1200/1200	1200	≤450	1702	3.5	
HBT-W1400/1400	1400	≤450	1985	3.5	
HBT-W1600/1600	1600	≤450	2265	3.5	

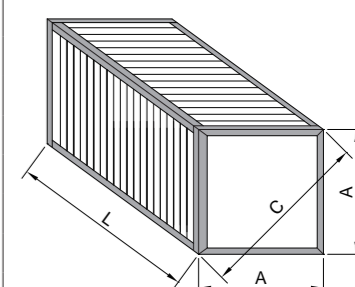

Remarks

1. The height of heat exchanger is customer-made, and the height of per single heat exchanger should be within the required range.
2. Size C is for reference only, can be adjusted according to the length of heat exchanger.

Air Handling Unit

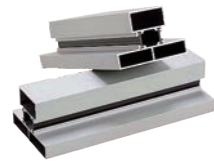

Upgraded insulation strip to make thermal bridge factor meet TB2<En 1886-2007> and air leakage ratio 0.94% according to <GB/T1429-2008> standards.



High strength aluminum alloy framework with AHU casing mechanical strength D1 grade according to <En 1886-2007>.

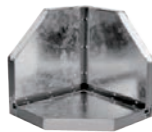

Sandwich panels are made with high density injection polyurethane insulation, meeting the thermal transmittance T2<En 1886-2007> standards.



Equipped with various of high-efficiency air-to-air heat recovery devices, such as heat recovery wheel, "U" heat pipe, plate heat exchanger, glycol circulation heat exchanger, to get the lowest energy and power consumption cost.

Professional selection program and modular design (1module=100mm) is providing customer with reasonable, economical, and practical solution.



Hinged/removable type access door are both available. Panel of AHU can be removed from outside, easy to disassemble at project site when necessary.



Variety of optional accessories, like water-proof service lamp, observation window, filter of all classes, air inlet and outlet damper(TOX connection technology), etc.



High performance water/DX coil with excellent heat transfer. Coil is made of copper pipe and aluminum fin.



Ceiling Suspended Air Handling Unit

- Airflow range 800m³/h ~ 10,000m³/h
- Double-skin PU panel
- Heat recovery available
- Customized functional section available
- Slim figure, easy for ceiling installation

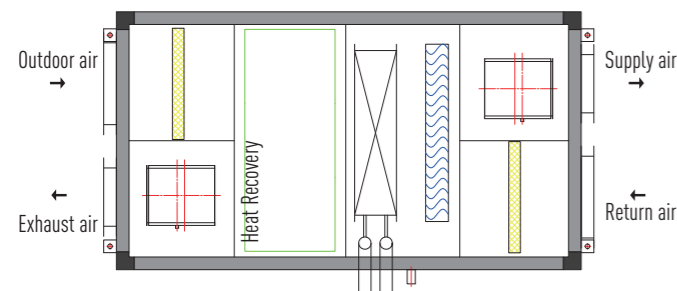

Combine Air Handling Unit

- Airflow range 1,000m³/h ~ 80,000m³/h
- 25S, 25U, 50U series double-skin PU panel
- Plate core/rotary wheel/heat pipe/glycol circulation heat recovery
- Variable functions available like cooling/heating/humidity control/purification/pressure control...
- Customization for every single project
- Performance comply to EU standard
- Widely used in commercial or industrial applications

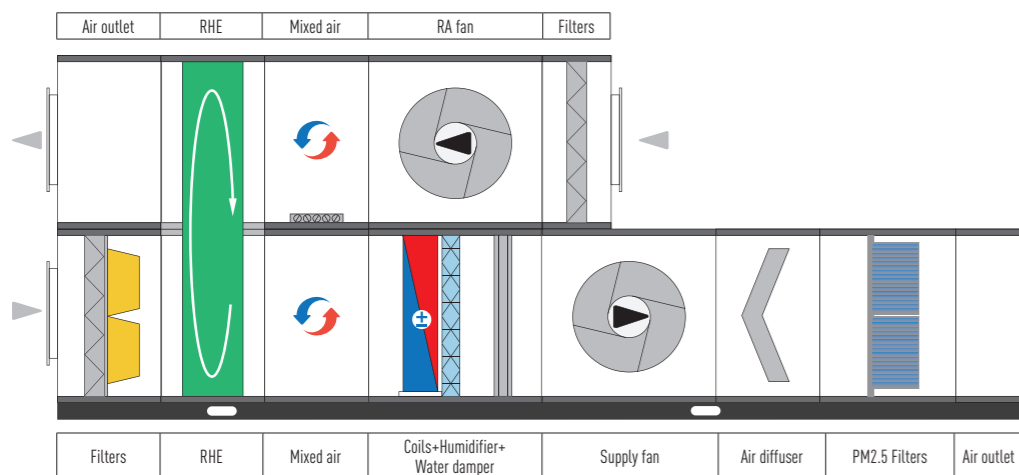

Industrial Air Handling Unit

- Airflow range 10,000m³/h ~ 320,000m³/h
- 50B, 80C, 80B series insulation casing
- Heat recovery available
- Gas combustion heating available
- Filtration for dust, fiber, paint mist, gas, and other particles
- Customization for every single project
- Industrial-grade, heavy duty, performance comply to EU standard
- Particularly for huge space, workshop with strict air condition control

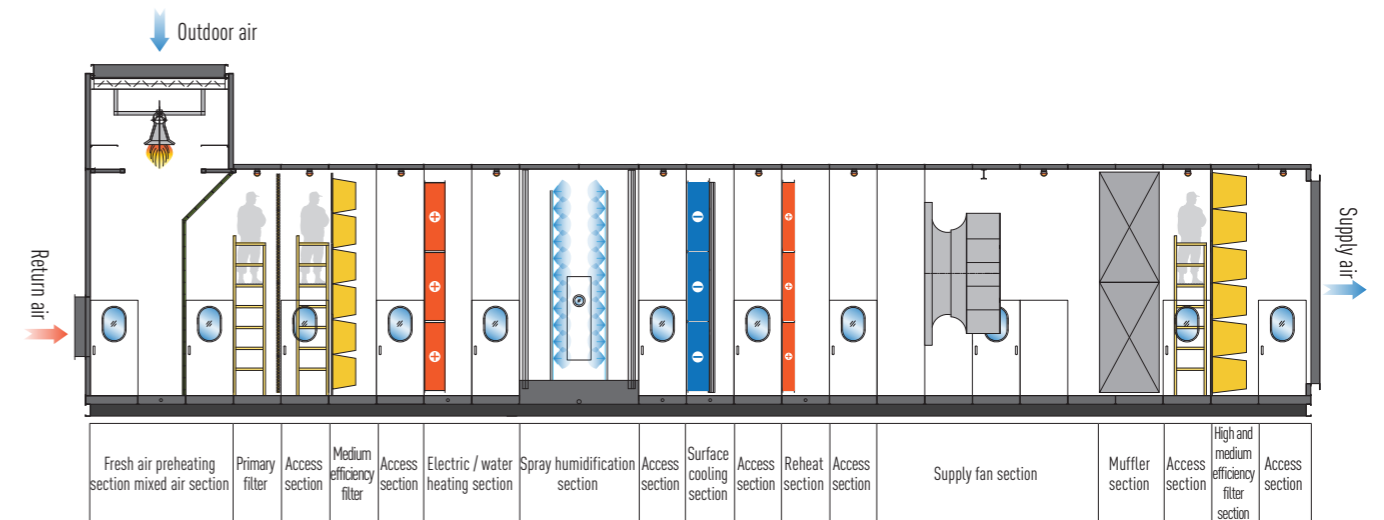

Applications



Rooftop Package Unit

- Airflow range 11,000m³/h ~ 34,000m³/h
- Double-skin PU panel
- Compact design with control box built in, low footprint
- Corrosion resistance, excellent weather conditions acclimatization
- Simplified system, lower investment, easy installation
- Wide Temperature Range Operation
- Customization available



DC Inverter DX Air Handling Unit

- DC inverter air-cooled outdoor unit
- Minimized power consumption, lower running cost
- Compatible with Combined Air Handling Unit
- Modular design, unit combination available
- Intelligent control and full protections
- Wide Temperature Range Operation



DC Inverter Heat Pump Heat Recovery Air Handling Unit

- Airflow range 600m³/h ~ 5000m³/h (suspended), 3000m³/h~30,000m³/h (floor type)
- Double-skin PU panel
- Plate core + heat pump dual recovery system, overall recovery efficiency up to 92%
- DC inverter compressor, minimized power consumption
- Compact design, packaged unit with built-in control box
- Regardless of extreme outdoor condition

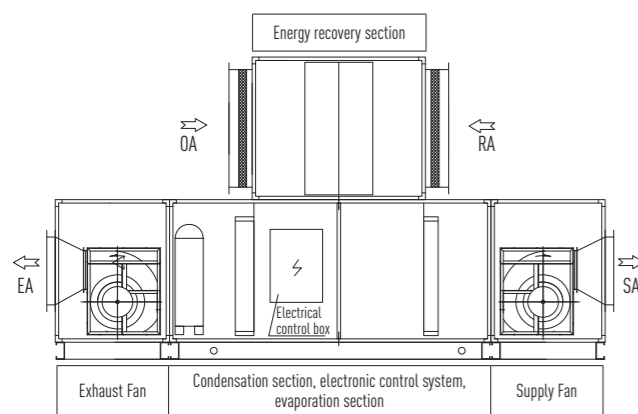

Air-Cooled Modular Chiller (Heat Pump)

- Modular design, latest technology
- Unit combination, group control available
- Smart defrosting, multiple protections
- Intelligent control and failure backup system
- Free access to upper control system
- Common type, low-temperature type, heat recovery type for options



Hospital Digital Intelligent Fresh Air Ventilation System

- Specially designed for hospital
- Apply high-efficiency equipment/device/component
- Control the air distribution and route to realize the air safety
- Satisfy minimum fresh air demand, to cut capacity load
- Pressure control to different area/department
- Real-time monitoring and satisfaction to minimum demand in each room
- Glycol circulation heat recovery
- Intelligent and highly centralized control system, available for mode definition

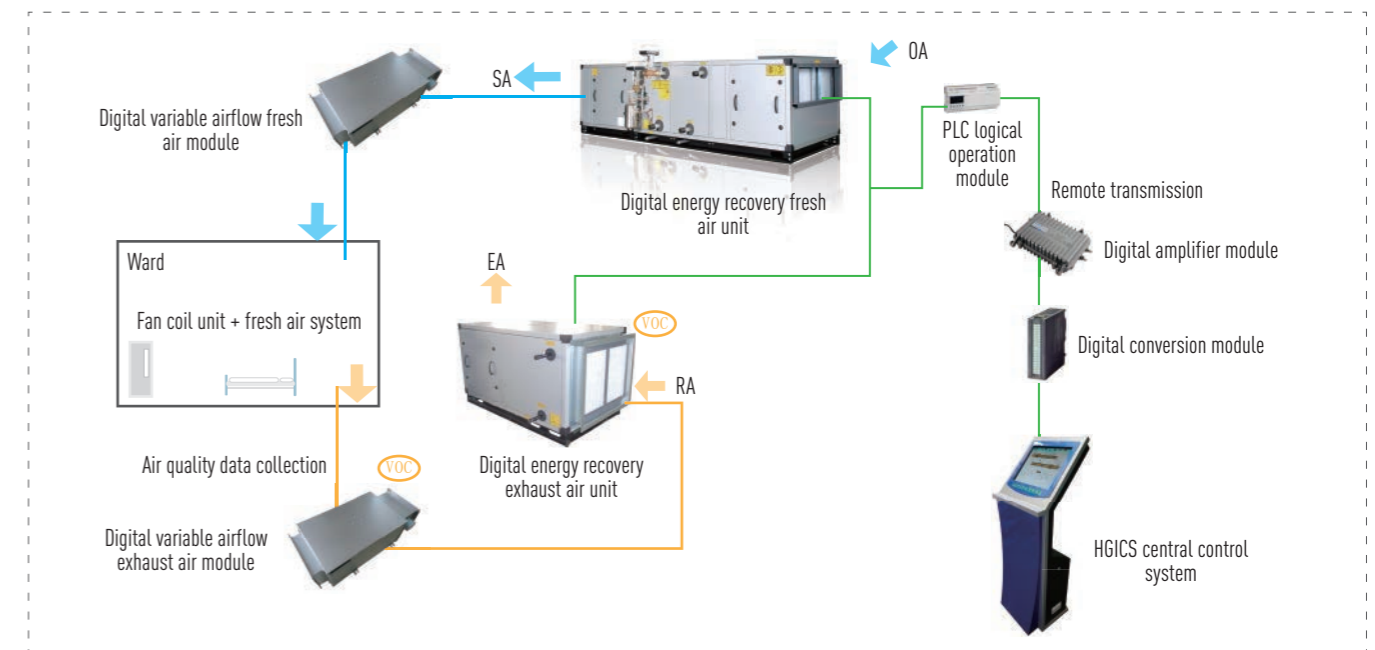

Solutions

- We offer solutions for
- Commercial buildings
 - Auto industry
 - Medical and pharmaceutical industry
 - Printing and food industry
 - VOC treatment and environment protection
 - Wind turbine nacelles and data centers

Our Services

- Consultancy
- Design
- Equipments supply
- Installation
- Maintenance



Certificates

After years of dedication to the research and technology development in the filed of heat recovery and indoor airquality, Holtop has many achievements on the product innovation and quality management, which are certified by National and International authorities.



■ Product Patent Certificates



■ Test lab Verification Certificates



■ Energy Saving Product Certificates

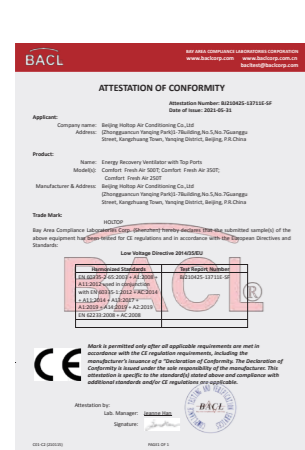

■ CE Certificate

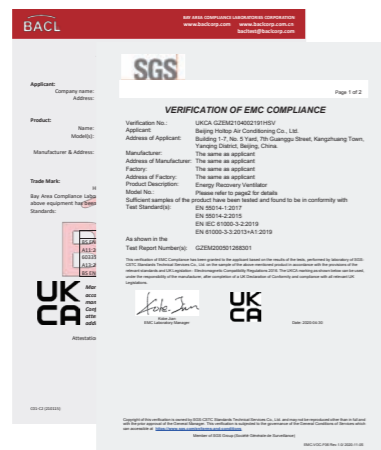

■ UKCA Certificate



■ ISO9001 / ISO14001 / OHSAS18001 Certificates

Job Reference

Projects & Cases Studies of Holtop Energy Recovery Solutions.

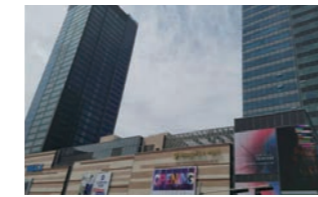

IMAX cinema, Mongolia, AHU



Samsung Electronics, Vietnam, RHE



Indoworth India Limited, India, Eco Vent ERV



Tokyo Inn, Germany, Eco Slim ERV



Geely Auto, Belarus, AHU



Health Center at Latsia, Cyprus, AHU



National Chung Cheng University, Taiwan, China, Eco Vent ERV



Fertilizer Plant, Bangladesh, AHU



Workington Academy, UK, Eco Smart ERV



Sofitel shopping mall stage-II, Pakistan, RHE

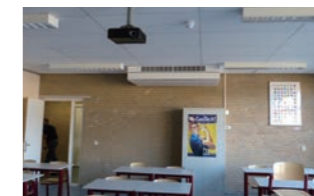

Primary School, Poland, Eco Vent ERV



Printing Factory, Malta, AHU



International Pharmaceutical Factory, Cambodia, AHU



Stanford University, USA, Eco Smart ERV



MeiLu villa residential project, Beijing, China, Eco Slim ERV



Mercedes Benz Auto factory, Beijing, China, AHU



Canton Tower, Guangzhou, China, RHE



World Expo Exhibition, Shanghai, China, AHU



2008 Olympic Games, Beijing, China, AHU



Ethiopian Airlines, Ethiopia, AHU

Cooperation Partners

